



Two-wire Serial EEPROM

BM24C16E

Bestow Mascot

CONTENT

1. Description.....	1
1.1 General Description	1
1.2 Features:	1
1.3 Package	1
2. Pin Descriptions.....	2
3. Block Diagram.....	3
4. Functional Description	4
4.1 Device Operation.....	4
4.2 Device Addressing	5
5. Instructions	6
5.1 Write Operations.....	6
5.2 Read Operations	7
6. Electrical Characteristics	9
6.1 Absolute Maximum Stress Ratings.....	9
6.2 Pin Capacitance.....	9
6.3 DC Electrical Characteristics	9
6.4 AC Electrical Characteristics	10
6.5 Reliability Characteristic ^[1]	11
6.6 Bus Timing.....	11
6.7 Write Cycle Timing	11
7. Ordering Information	12
7.1 Naming Scheme	12
7.2 Order Information	13
7.3 DIP8 Package Outline Dimensions	14
7.4 SOP8 Package Outline Dimensions.....	15
7.5 TSSOP8 Package Outline Dimensions.....	16
7.6 SOT23-5 Package Outline Dimensions	17
7.7 DFN8 Package Outline Dimensions	18
7.8 Tube and Reel Information	19
8. Notice	20
9. Revision History.....	23

1. Description

1.1 General Description

The BM24C16E is a 16-Kbit I²C-compatible Serial EEPROM (Electrically Erasable Programmable Memory) device. It contains a memory array of 2048× 8 bits, which is 16-byte per page. The device is optimized for use in many industrial and commercial applications where low-power and low-voltage operation are essential. The BM24C16E is available in space-saving 8-lead DIP8/SOP8/ TSSOP8/DFN8 SOT23-5 and CSP4 packages and is accessed via a two-wire serial interface.

1.2 Features:

- Single Supply Voltage and High Speed
 - ✧ Minimum operating voltage down to 1.7V
 - ✧ 1 MHz clock from 2.5V to 5.5V
 - ✧ 400kHz clock from 1.7V to 2.5V
- Operating Ambient Temperature: -40°C to +125°C
- Low power CMOS technology
 - ✧ Read current 400uA, maximum
 - ✧ Write current 1.6mA, maximum
- Schmitt Trigger, Filtered Inputs for Noise Suppression
- Sequential & Random Read Features
- Page Write Modes
- Partial Page Writes Allowed
- Write Protect of the Whole Memory Array
- Self-timed Write Cycle (5 ms max)
- High Reliability
 - ✧ Endurance: >1 Million Write Cycles
 - ✧ Data Retention: >100 Years
 - ✧ Latch up Capability: +/- 200mA

1.3 Package

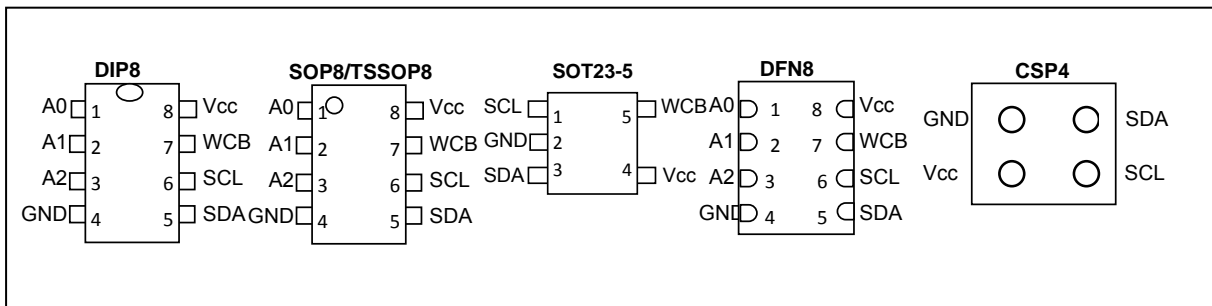

2. Pin Descriptions

Pin number	Designation	Name and Functions
1 – 3	A0 - A2	Device Addresses (A2, A1, A0): The A2, A1, and A0 pins are device address inputs. Typically, the A2, A1, and A0 pins are for hardware addressing and a total of 8 devices can be connected on a single bus system. If these pins are left floating, the A2, A1, and A0 pins will be internally pulled down to GND.
4	GND	Ground
5	SDA	Serial Data (SDA): The SDA pin is bidirectional for serial data transfer. This pin is open drain driven and may be wire-OR'ed with any number of other open-drain or open-collector devices.
6	SCL	Serial Clock (SCL): The SCL input is used to positive-edge clock data in and negative-edge clock data out of each device.
7	WCB	Write Control (WCB): The Write Control input, when WCB is connected directly to V _{CC} , all write operations to the memory are inhibited. When connected to GND, allows normal write operations. If the pin is left floating, the WCB pin will be internally pulled down to GND.
8	V _{CC}	Power Supply

3. Block Diagram

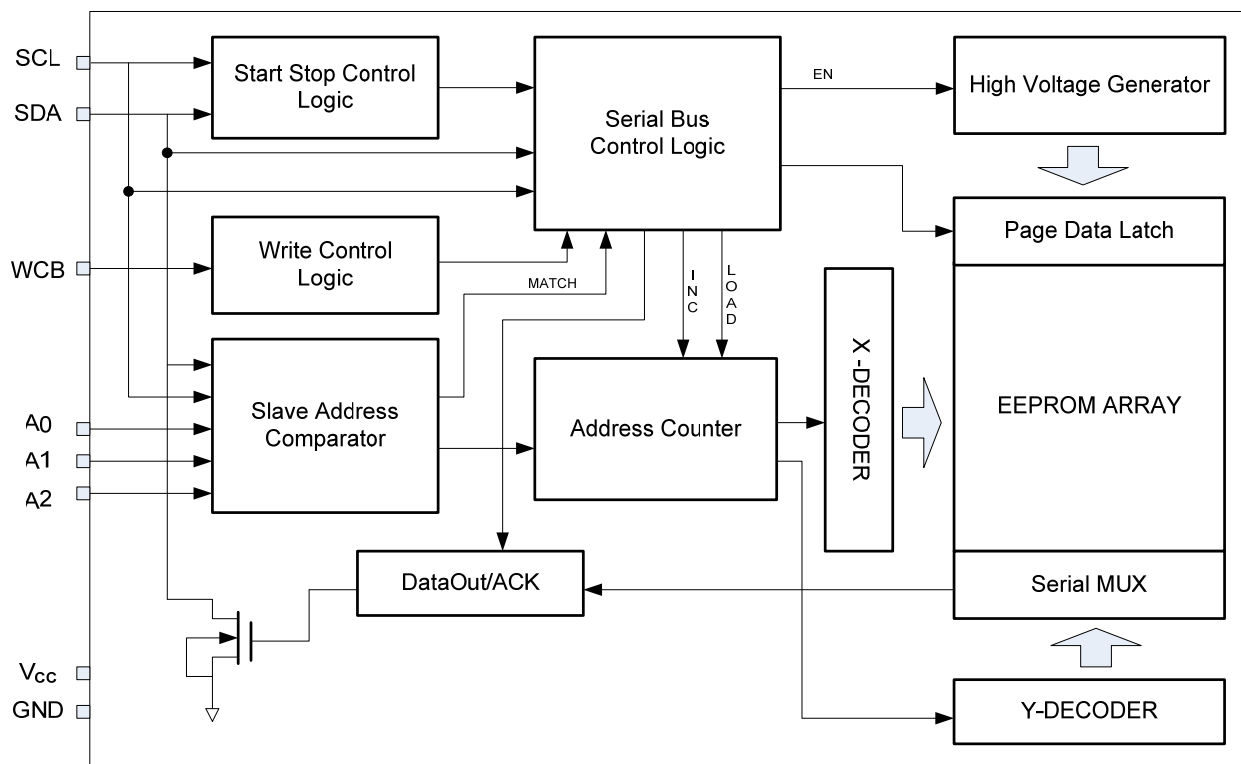

4. Functional Description

4.1 Device Operation

CLOCK and DATA TRANSITIONS: The SDA pin is normally pulled high with an external device. Data on the SDA pin may change only during SCL low time periods (see to Figure 1). Data changes during SCL high periods will indicate a start or stop condition as defined below.

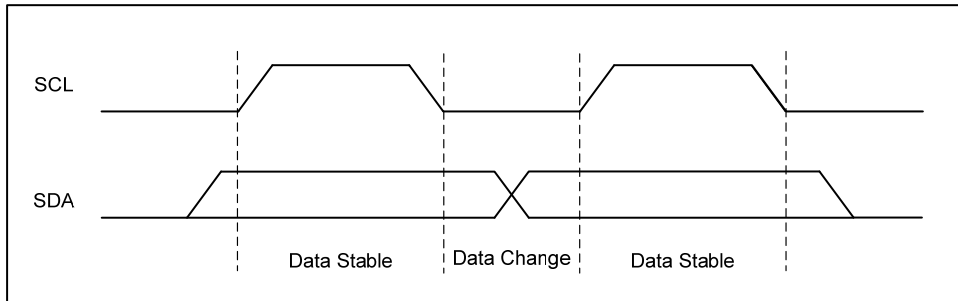

Figure1 Data Validity

START CONDITION: A high-to-low transition of SDA with SCL high is a start condition which must precede any other command (see to Figure 2).

STOP CONDITION: A low-to-high transition of SDA with SCL high is a stop condition. After a read sequence, the stop command will place the EEPROM in a standby power mode (see Figure 2).

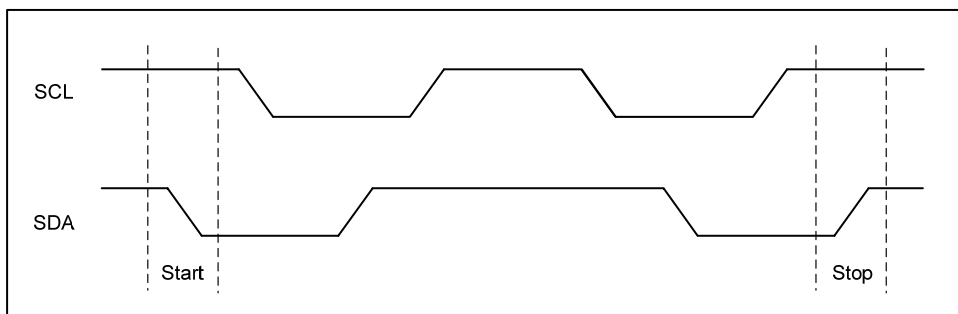

Figure2 Start and Stop Definition

ACKNOWLEDGE: All addresses and data words are serially transmitted to and from the EEPROM in 8-bit words. The BM24C16E sends a “0” to acknowledge that it has received each word. This happens during the ninth clock cycle.

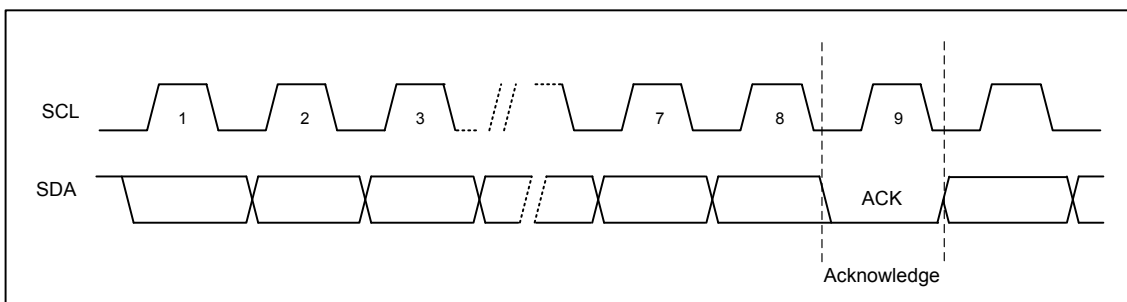

Figure3 Output Acknowledge

STANDBY MODE: The BM24C16E features a low-power standby mode which is enabled:

- (a) after a fresh power up,
- (b) after receiving a STOP bit in read mode,

(c) after completing a self-time internal programming operation

MEMORY RESET: After an interruption in protocol, power loss or system reset, any two-wire part can be reset by following these steps: (a) Create a start condition, (b) Clock nine cycles, and (c) create another start bit followed by stop bit condition, as shown below. The device is ready for the next communication after the above steps have been completed.

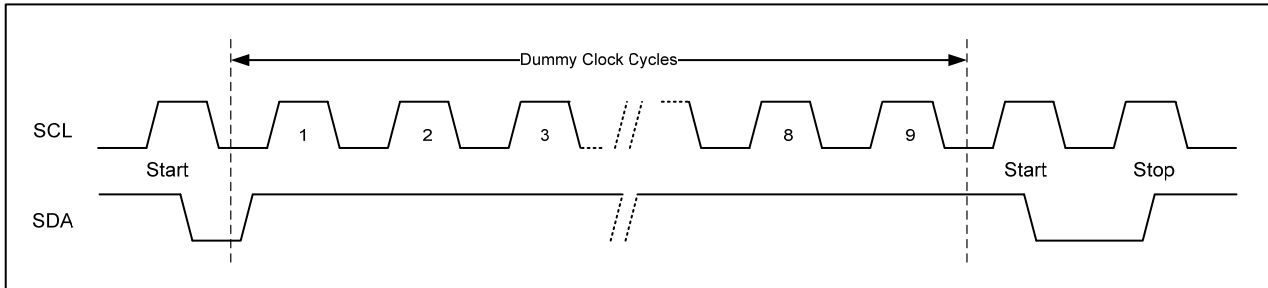

Figure4 Soft Reset

4.2 Device Addressing

The BM24C16E require an 8-bit device address word following a start condition to enable the chip for a read or write operation (see table below).

The device address word consists of a mandatory "1", "0" sequence for the first four most significant bits.

Device Address

Access area	Bit 7	Bit 6	Bit 5	Bit 4	Bit 3	Bit 2	Bit 1	Bit 0
Normal Area	1	0	1	0	P2	P1	P0	R/W
ID Page	1	0	1	1	X	X	X	R/W
Lock Bit	1	0	1	1	X	X	X	R/W
Serial Number	1	0	1	1	X	X	X	1

Word Address

Data	Bit 7	Bit 6	Bit 5	Bit 4	Bit 3	Bit 2	Bit 1	Bit 0
Normal Area	A7	A6	A5	A4	A3	A2	A1	A0
ID Page	0	0	A5	A4	A3	A2	A1	A0
Lock Bit	X	1	X	X	X	X	X	X
Serial Number	1	0	A5	A4	A3	A2	A1	A0

The three A2, A1, and A0 device address bits allow as many as eight devices on the same bus.

These bits must compare to their corresponding hardwired input pins.

The A2, A1, and A0 pins use an internal proprietary circuit that biases them to a logic low condition if the pins are floating.

The eighth bit of the device address is the read/write operation select bit. A read operation is initiated if this bit is high and a write operation is initiated if this bit is low. Upon a compare of the device address, the Chip will output a zero. If a compare is not made, the device will return to a standby state.

DATA SECURITY: The BM24C16E has a hardware data protection scheme that allows the user to write protect the entire memory when the WCB pin is at V_{CC}.

5. Instructions

5.1 Write Operations

BYTE WRITE: A write operation requires one 8-bit data word address following the device address word and acknowledgment. Upon receipt of this address, the BM24C16E will again respond with a “0” and then clock in the first 8-bit data word. Following receipt of the 8-bit data word, the BM24C16E will output a “0” and the addressing device, such as a microcontroller, must terminate the write sequence with a stop condition. At this time the EEPROM enters an internally timed write cycle, to the nonvolatile memory. All inputs are disabled during this write cycle and the EEPROM will not respond until the write is complete (see Figure 5).

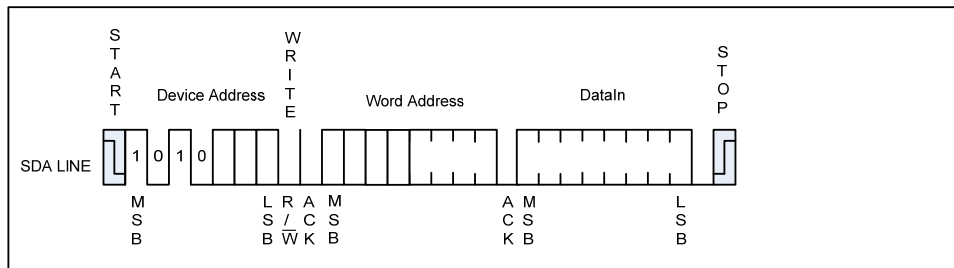

Figure5 Byte Write

PAGE WRITE:

A page write is initiated the same as a byte write, but the microcontroller does not send a stop condition after the first data word is clocked in. Instead, after the EEPROM acknowledges receipt of the first data word, the microcontroller can transmit more data words. The EEPROM will respond with a "0" after each data word received.

The microcontroller must terminate the page write sequence with a stop condition (see Figure 6).

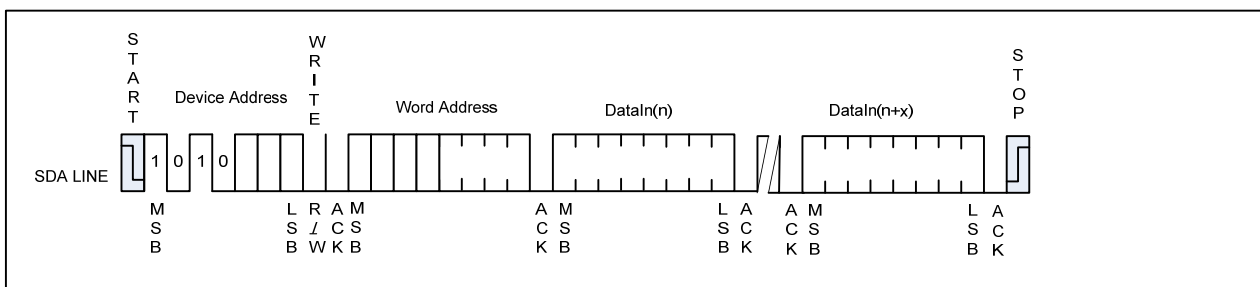

Figure6 Page Write

The data word address lower six bits are internally incremented following the receipt of each data word.

The higher data word address bits are not incremented, retaining the memory page row location. When the word address, internally generated, reaches the page boundary, the following byte is placed at the beginning of the same page. If more than 16 data words are transmitted to the EEPROM, the data word address will "roll over" and previous data will be overwritten. The address roll-over during write is from the last byte of the current page to the first byte of the same page.

ACKNOWLEDGE POLLING: Once the internally timed write cycle has started and the EEPROM inputs are disabled, acknowledge polling can be initiated. This involves sending a start condition followed by the

device address word. The read/write bit is representative of the operation desired. Only if the internal write cycle has completed will the EEPROM respond with a “0”, allowing the read or write sequence to continue.

5.2 Read Operations

Read operations are initiated the same way as write operations with the exception that the read/write select bit in the device address word is set to “1”. There are three read operations: current address read, random address read and sequential read.

CURRENT ADDRESS READ: The internal data word address counter maintains the last address accessed during the last read or write operation, incremented by one. This address stays valid between operations as long as the chip power is maintained. The address “roll over” during read is from the last byte of the last memory page to the first byte of the first page.

Once the device address with the read/write select bit set to “1” is clocked in and acknowledged by the EEPROM, the current address data word is serially clocked out. The microcontroller does not respond with an input “0” but does generate a following stop condition (see Figure 7).

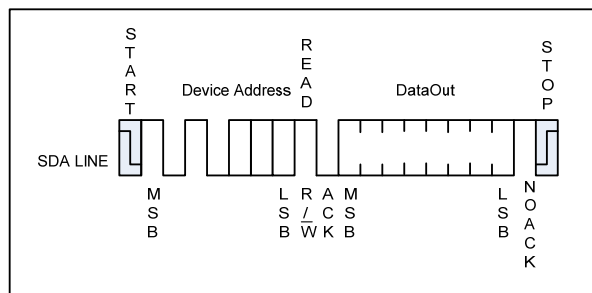

Figure7 Current Address Read

RANDOM READ: A random read requires a “dummy” byte write sequence to load in the data word address. Once the device address word and data word address are clocked in and acknowledged by the EEPROM, the microcontroller must generate another start condition. The microcontroller now initiates a Current Address Read by sending a device address with the read/write select bit high. The EEPROM acknowledges the device address and serially clocks out the data word. The microcontroller does not respond with a “0” but does generate a following stop condition (see Figure 8).

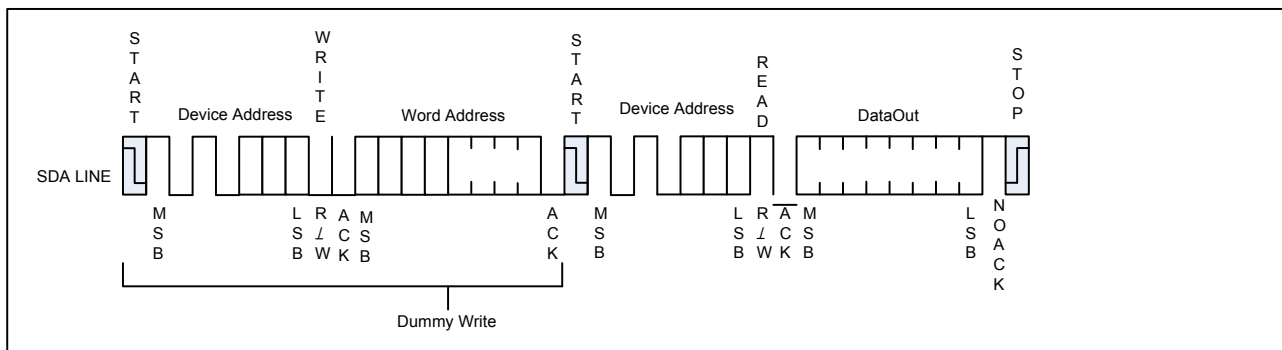

Figure8 Random Read

SEQUENTIAL READ: Sequential reads are initiated by either a current address read or a random address read. After the microcontroller receives a data word, it responds with an acknowledge. As long as the EEPROM receives an acknowledge, it will continue to increment the data word address and serially clock out sequential data words. When the memory address limit is reached, the data word address will “roll over” and the sequential read will continue. The sequential read operation is terminated when the microcontroller does not respond with a “0” but does generate a following stop condition (see Figure 9)

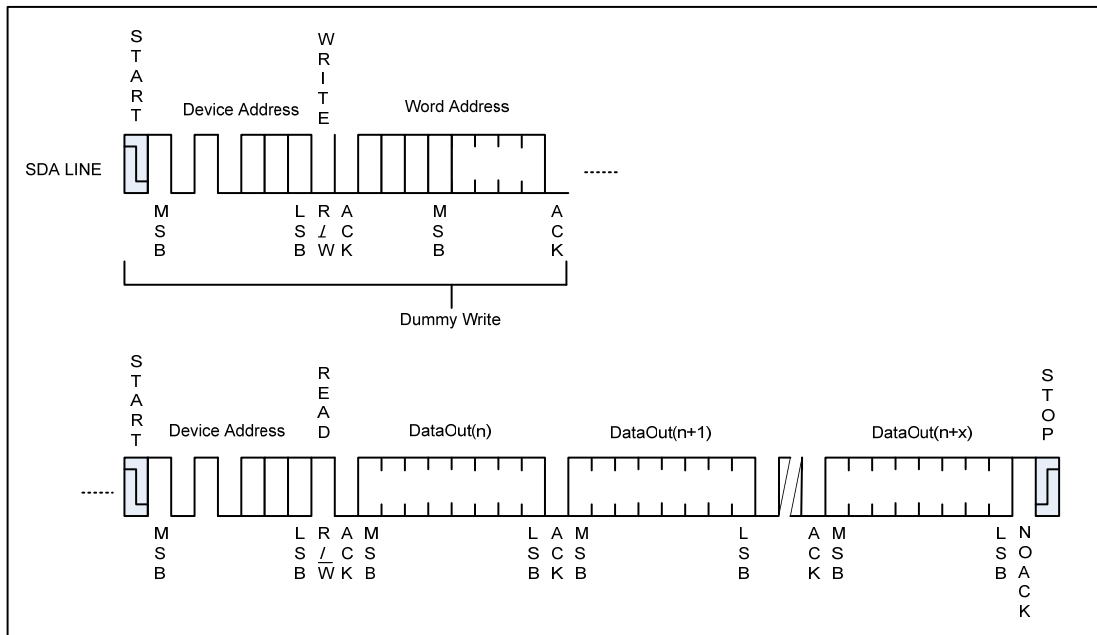

Figure9 Sequential Read

6. Electrical Characteristics

6.1 Absolute Maximum Stress Ratings

- Maximum Operation Voltage..... 6.25V
- Voltage on Any Pin with Respect to Ground.....-1.0V to (V_{CC}+1.0) V
- DC Output Current5.0 mA
- Operating Ambient Temperature-40°C to +125°C
- Storage Temperature.....-65°C to +150°C

Comments: Stresses above those listed under "Absolute Maximum Ratings" may cause permanent damage to this device. These are stress ratings only. Functional operation of this device at these or any other conditions above those indicated in the operational sections of this specification is not implied or intended. Exposure to the absolute maximum rating conditions for extended periods may affect device reliability.

6.2 Pin Capacitance

Symbol	Parameter	Max.	Units	Test Condition
C _{I/O}	Input/Output Capacitance (SDA)	8	pF	V _{I/O} =GND
C _{IN}	Input Capacitance (A0,A1,A2,WCB,SCL)	6	pF	V _{IN} =GND

Note: Test Conditions: T_A = 25°C, F = 1MHz, V_{CC} = 5.0V.

6.3 DC Electrical Characteristics

Symbol	Parameter	Min.	Typ.	Max.	Unit	Test Condition
V _{CC}	Supply Voltage	1.7	-	5.5	V	-
I _{sb}	Standby Current	-	-	1.0	uA	V _{CC} = 3.3V, T _A = 85°C
		-	-	3.0	uA	V _{CC} = 5.5V, T _A = 85°C
		-	-	6.0	uA	V _{CC} = 5.5V, T _A = 105°C
		-	-	10.0	uA	V _{CC} = 5.5V, T _A = 125°C
I _{CC1}	Supply Current	-	0.2	0.4	mA	V _{CC} =5.5V, Read at 400Khz
I _{CC2}	Supply Current	-	0.8	1.6	mA	V _{CC} =5.5V Write at 400Khz
I _{LI}	Input Leakage Current	-	0.10	1.0	uA	V _{IN} = V _{CC} or GND
I _{LO}	Output Leakage Current	-	0.05	1.0	uA	V _{OUT} = V _{CC} or GND
V _{IL}	Input Low Level	-0.6	-	0.3V _{CC}	V	-
V _{IH}	Input High Level	0.7V _{CC}	-	V _{CC} +0.5	V	-
V _{OL1}	Output Low Level V _{CC} = 1.7V (SDA)	-	-	0.2	V	I _{OL} = 1.5 mA

Symbol	Parameter	Min.	Typ.	Max.	Unit	Test Condition
V_{OL2}	Output Low Level $V_{CC} = 3.0V$ (SDA)	-	-	0.4	V	$I_{OL} = 2.1\text{ mA}$

Note: Unless otherwise specified, $V_{CC} = 1.7V$ to $5.5V$, $T_A = -40^{\circ}C$ to $125^{\circ}C$

6.4 AC Electrical Characteristics

Symbol	Parameter	$1.7 \leq V_{CC} < 2.5$			$2.5 \leq V_{CC} \leq 5.5$			Units
		Min.	Typ.	Max.	Min.	Typ.	Max.	
f_{SCL}	Clock Frequency, SCL	-	-	400	-	-	1000	kHz
t_{LOW}	Clock Pulse Width Low	1.3	-	-	0.4	-	-	μs
t_{HIGH}	Clock Pulse Width High	0.6	-	-	0.4	-	-	μs
t_{AA}	Clock Low to Data Out Valid	0.05	-	0.9	0.05	-	0.55	μs
t_i	Noise Suppression Time	-	-	0.1	-	-	0.05	μs
t_{BUF}	Time the bus must be free before a new transmission can start	1.3	-	-	0.5	-	-	μs
$t_{HD.STA}$	Start Hold Time	0.6	-	-	0.25	-	-	μs
$t_{SU.STA}$	Start Setup Time	0.6	-	-	0.25	-	-	μs
$t_{HD.DAT}$	Data In Hold Time	0	-	-	0	-	-	μs
$t_{SU.DAT}$	Data In Setup Time	0.1	-	-	0.1	-	-	μs
t_R	Inputs Rise Time ^[1]	-	-	0.3	-	-	0.3	μs
t_F	Inputs Fall Time ^[1]	-	-	0.3	-	-	0.1	μs
$t_{SU.STO}$	Stop Setup Time	0.6	-	-	0.25	-	-	μs
t_{DH}	Data Out Hold Time	0.05	-	-	0.05	-	-	μs
$t_{SU.WCB}$	WCB pin Setup Time	1.2	-	-	0.6	-	-	μs
$t_{HD.WCB}$	WCB pin Hold Time	1.2	-	-	0.6	-	-	μs
t_{WR}	Write Cycle Time	-	-	5	-	-	5	ms

Notes: Unless otherwise specified, $V_{CC} = 1.7V$ to $5.5V$, $T_A = -40^{\circ}C$ to $125^{\circ}C$, $C_L = 100pF$, Test Conditions are listed in Notes2.

[1] This parameter is ensured by characterization not 100% tested

[2] AC measurement conditions:

- ✧ R_L (connects to V_{CC}): 1.3k (2.5V, 5.5V), 10k (1.7V)
- ✧ Input pulse voltages: $0.3 V_{CC}$ to $0.7 V_{CC}$
- ✧ Input rise and fall times: $\leq 50ns$
- ✧ Input and output timing reference voltages: $0.5V_{CC}$

6.5 Reliability Characteristic^[1]

Symbol	Parameter	Min.	Typ.	Max.	Unit
EDR ^[2]	Endurance	1,000,000	-	-	Write cycles
DRET	Data retention	100	-	-	Years

Note: [1] This parameter is ensured by characterization and is not 100% tested

[2] Under the condition: 25°C, 3.3V, Page mode

6.6 Bus Timing

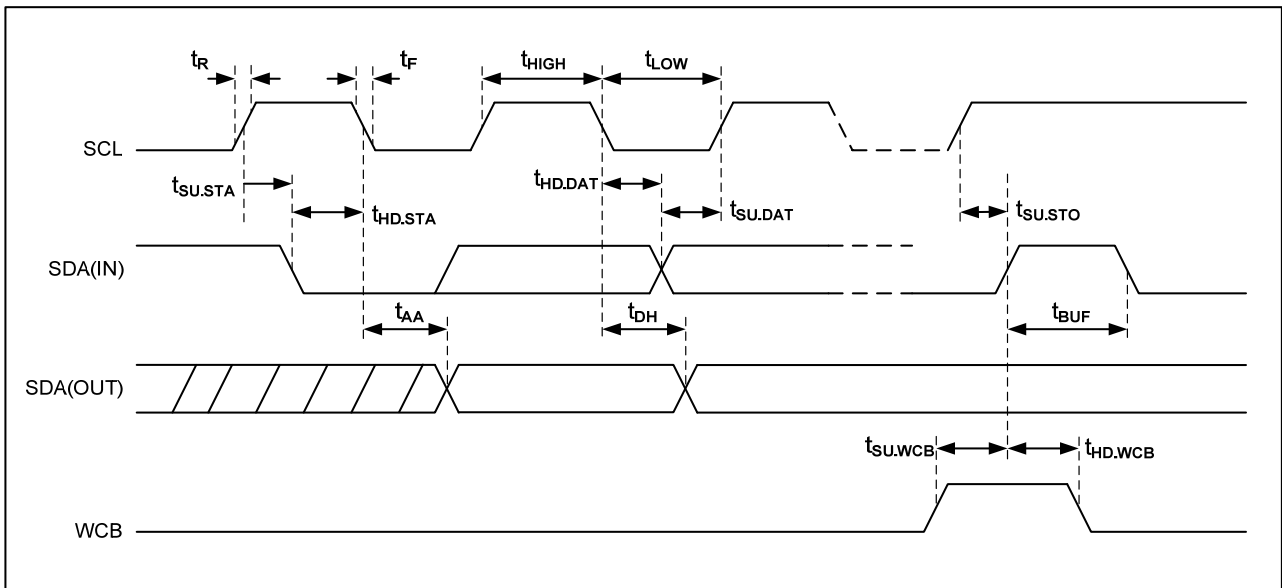
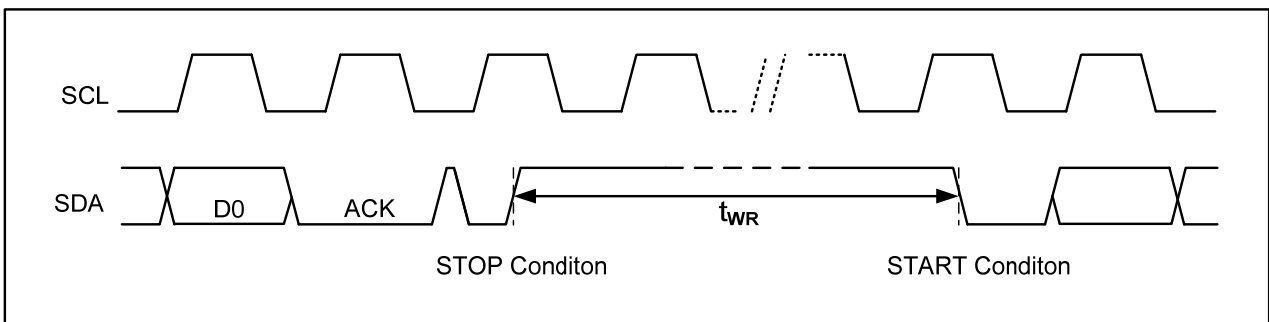

Figure10 Bus Timing

6.7 Write Cycle Timing



Note: The write cycle time t_{WR} is the time from a valid stop condition of a write sequence to the end of the internal clear/write cycle.

Figure11 Write Cycle Timing

7. Ordering Information

7.1 Naming Scheme

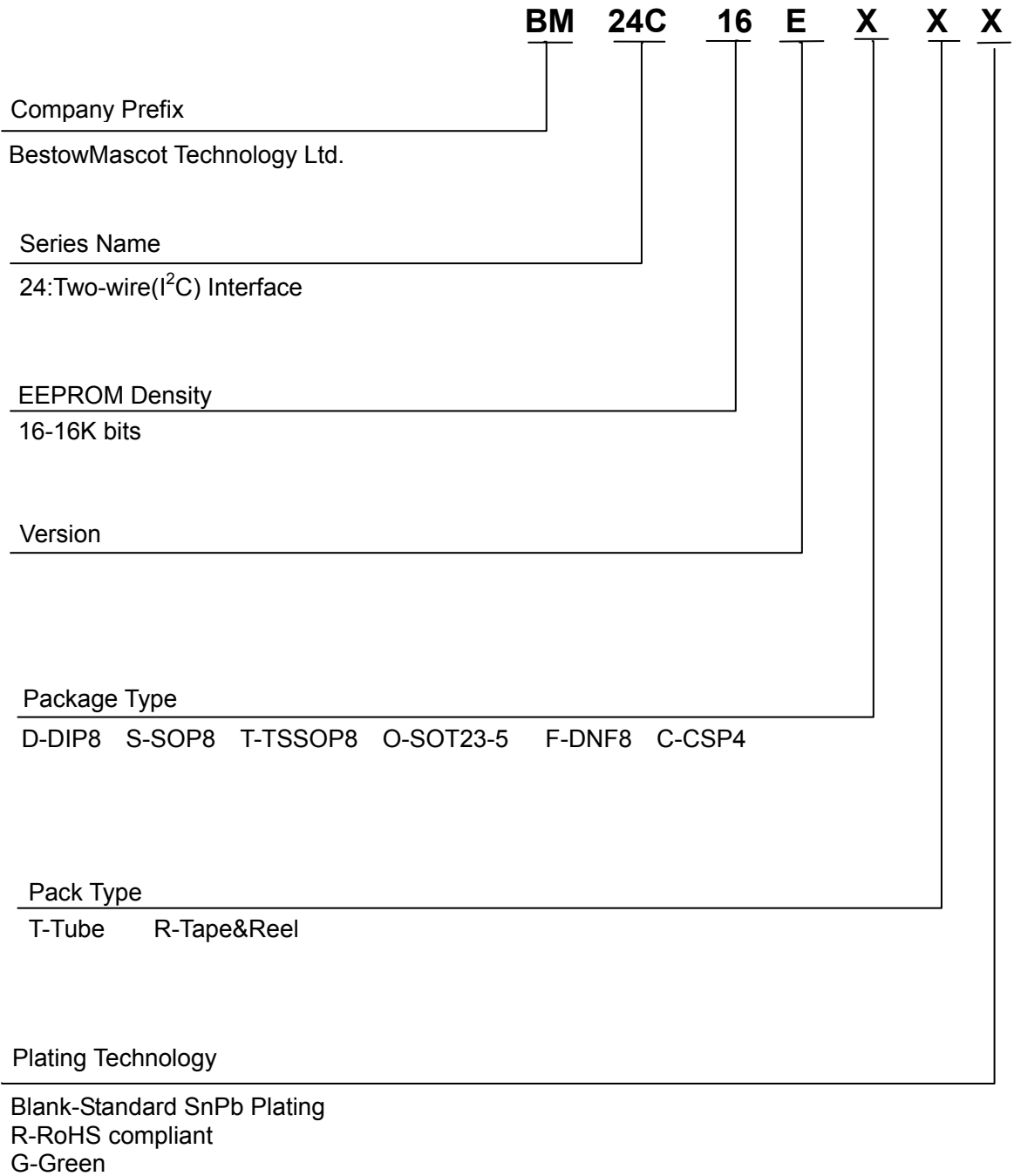

Model	DIP8	SOP8	TSSOP8	SOT23-5	DFN8	CSP4
BM24C16E	√	√	√	√	√	-

√: Mass-produced

*: Design in

-: Be customize

7.2 Order Information

Package	Temperature Range	Vcc	HSF	Packaging	Order Code
DIP8	-40°C-125°C	1.7V-5.5V	Green	Tube	BM24C16E-D-T-G
SOP8	-40°C-125°C	1.7V-5.5V	Green	Tube	BM24C16E-S-T-G
				Tape and Reel	BM24C16E-S-R-G
TSSOP8	-40°C-125°C	1.7V-5.5V	Green	Tube	BM24C16E-T-T-G
				Tape and Reel	BM24C16E-T-R-G
SOT23-5	-40°C-125°C	1.7V-5.5V	Green	Tape and Reel	BM24C16E-O-R-G
DFN8	-40°C-125°C	1.7V-5.5V	Green	Tape and Reel	BM24C16E-F-R-G
CSP4	-40°C-125°C	1.7V-5.5V	Green	Tape and Reel	BM24C16E-C-R-G

7.3 DIP8 Package Outline Dimensions

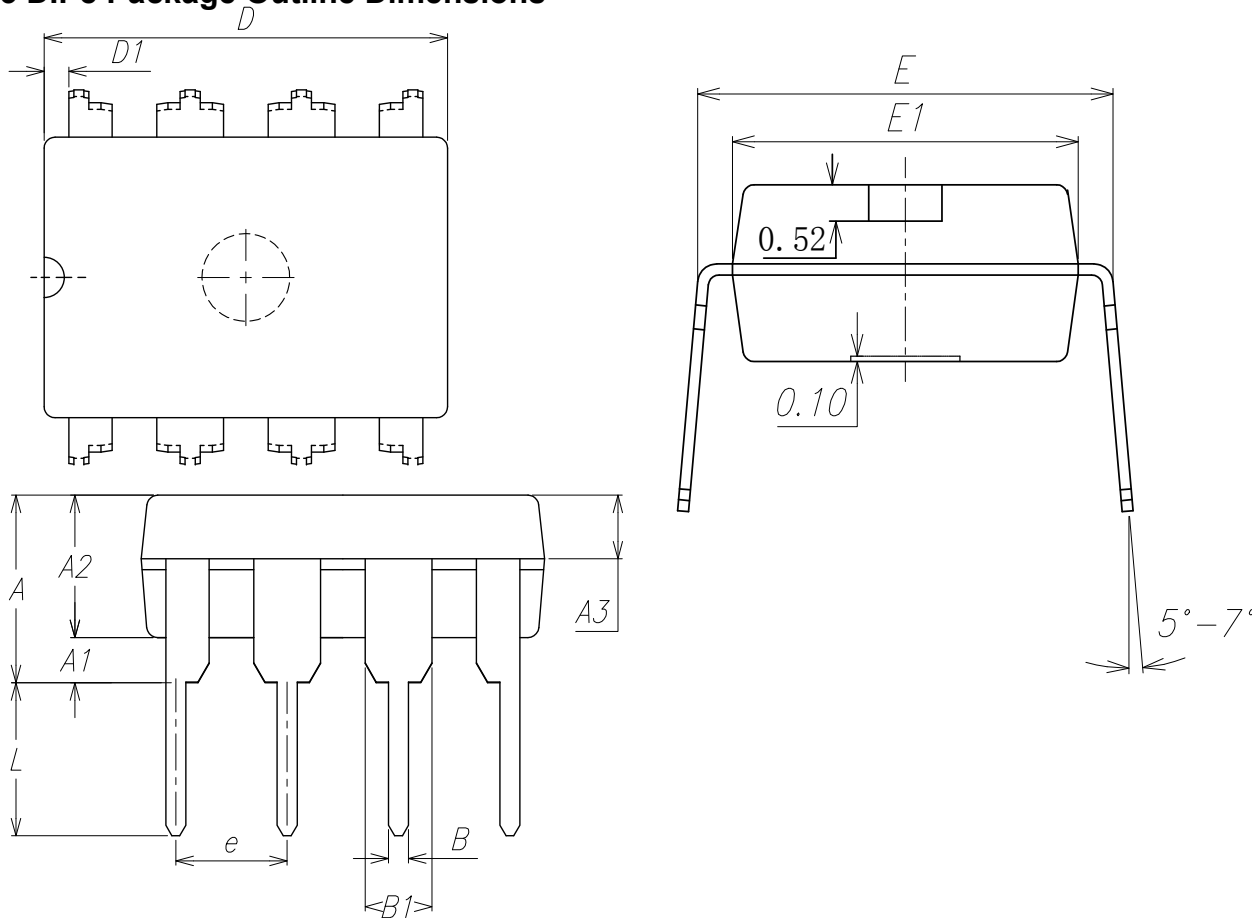

Symbol	Dimensions In Millimeters		Dimensions In Inches	
	Min	Max	Min	Max
A	3.60	4.00	0.142	0.157
A1	0.51	-	0.020	-
A2	3.10	3.50	0.122	0.138
A3	1.50	1.70	0.059	0.067
B	0.44	0.53	0.017	0.021
B1	1.52	1.57	0.060	0.062
D	9.20	9.25	0.362	0.364
D1	0.561	0.611	0.022	0.024
E	7.63	7.68	0.300	0.302
E1	6.35	6.40	0.250	0.252
e	2.54BSC		0.100 BSC	
L	3.49	3.81	0.138	0.150

7.4 SOP8 Package Outline Dimensions

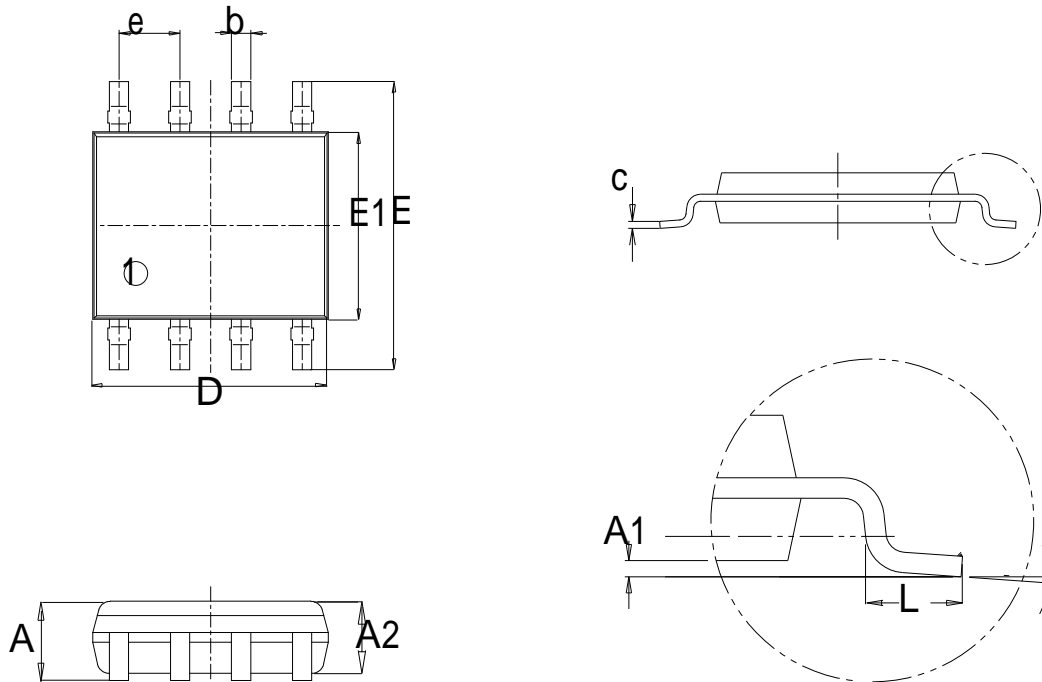

Symbol	Dimensions In Millimeters		Dimensions In Inches	
	Min	Max	Min	Max
A	1.350	1.650	0.053	0.065
A1	0.100	0.250	0.004	0.010
A2	1.450	1.525	0.057	0.060
b	0.375	0.425	0.015	0.017
c	0.245 (BSC)		0.010 (BSC)	
D	4.875	4.925	0.192	0.194
E	5.900	6.100	0.232	0.240
E1	3.825	3.925	0.151	0.155
e	1.245	1.295	0.049	0.051
L	0.615	0.765	0.024	0.030
α	0°	5°	0°	5°

7.5 TSSOP8 Package Outline Dimensions

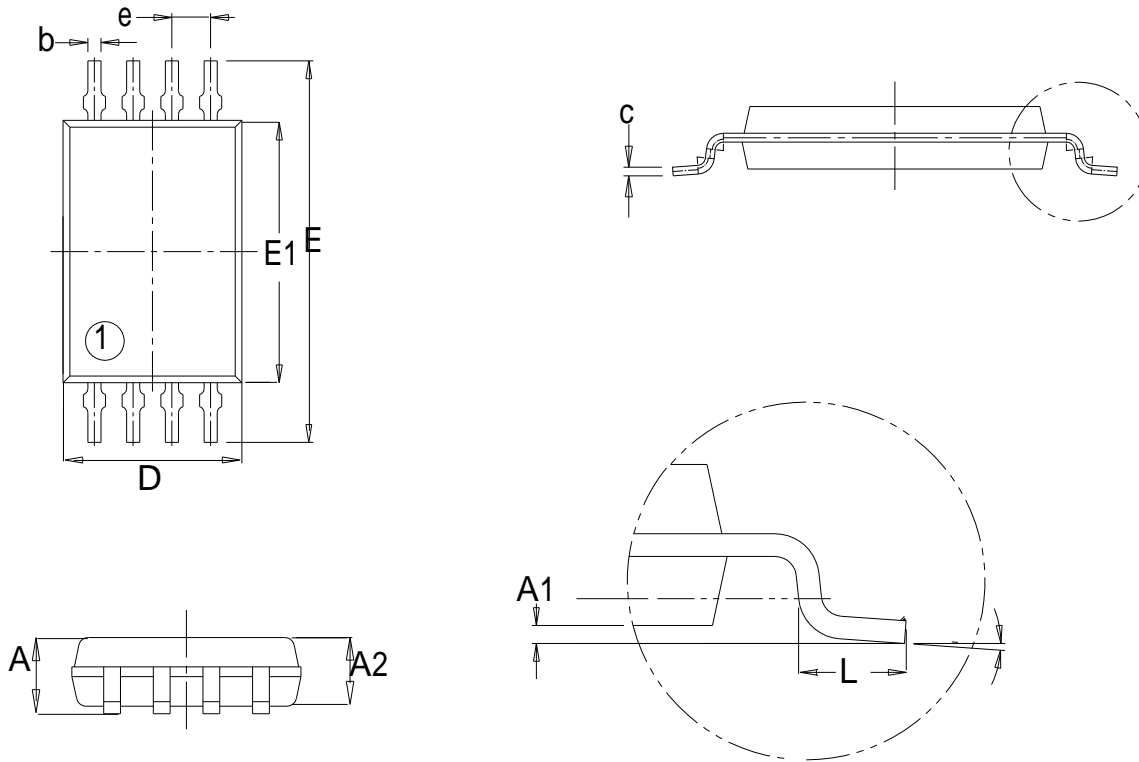

Symbol	Dimensions In Millimeters		Dimensions In Inches	
	Min	Max	Min	Max
A	0.850	1.100	0.033	0.043
A1	0.070	0.130	0.003	0.005
A2	0.850	0.900	0.033	0.035
b	0.195	0.245	0.008	0.010
c	0.127 (BSC)		0.005 (BSC)	
D	2.910	3.030	0.115	0.119
E	6.230	6.480	0.245	0.255
E1	4.370	4.430	0.172	0.174
e	0.625	0.675	0.025	0.027
L	0.562	0.638	0.022	0.025
α	1°	7°	1°	7°

7.6 SOT23-5 Package Outline Dimensions

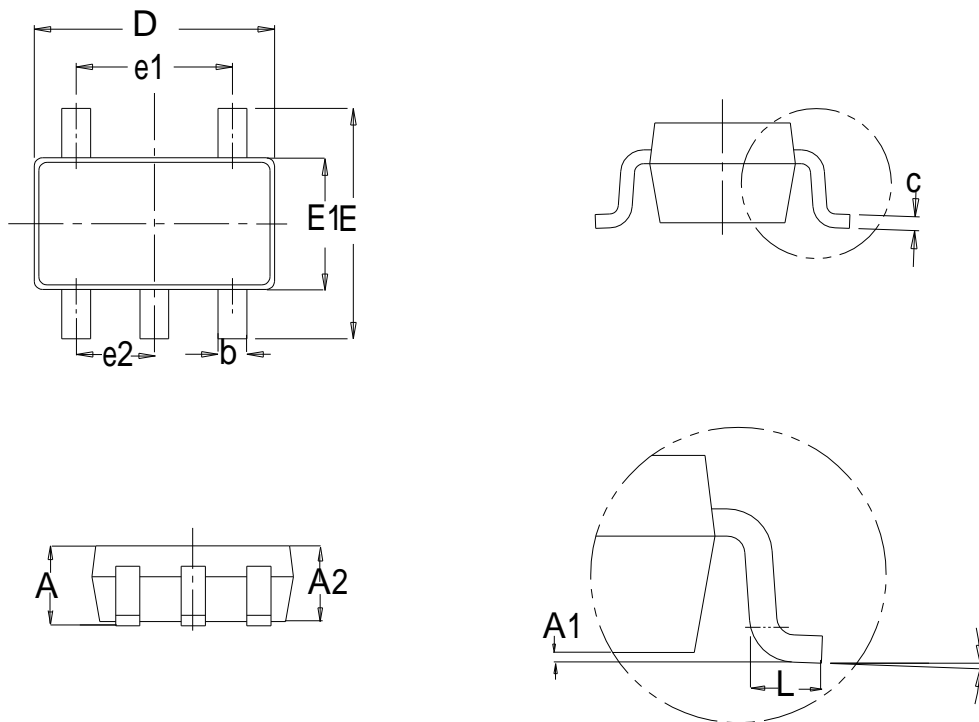

Symbol	Dimensions In Millimeters		Dimensions In Inches	
	Min	Max	Min	Max
A	1.050	1.250	0.041	0.049
A1	0.000	0.150	0.000	0.006
A2	1.000	1.200	0.039	0.047
b	0.330	0.500	0.013	0.020
c	0.140	0.200	0.006	0.008
D	2.800	3.020	0.110	0.119
E	2.600	3.000	0.102	0.118
E1	1.500	1.700	0.059	0.067
e1	1.900 (BSC)		0.075 (BSC)	
e2	0.950 (BSC)		0.037 (BSC)	
L	0.350	0.600	0.014	0.024
α	0°	8°	0°	8°

7.7 DFN8 Package Outline Dimensions

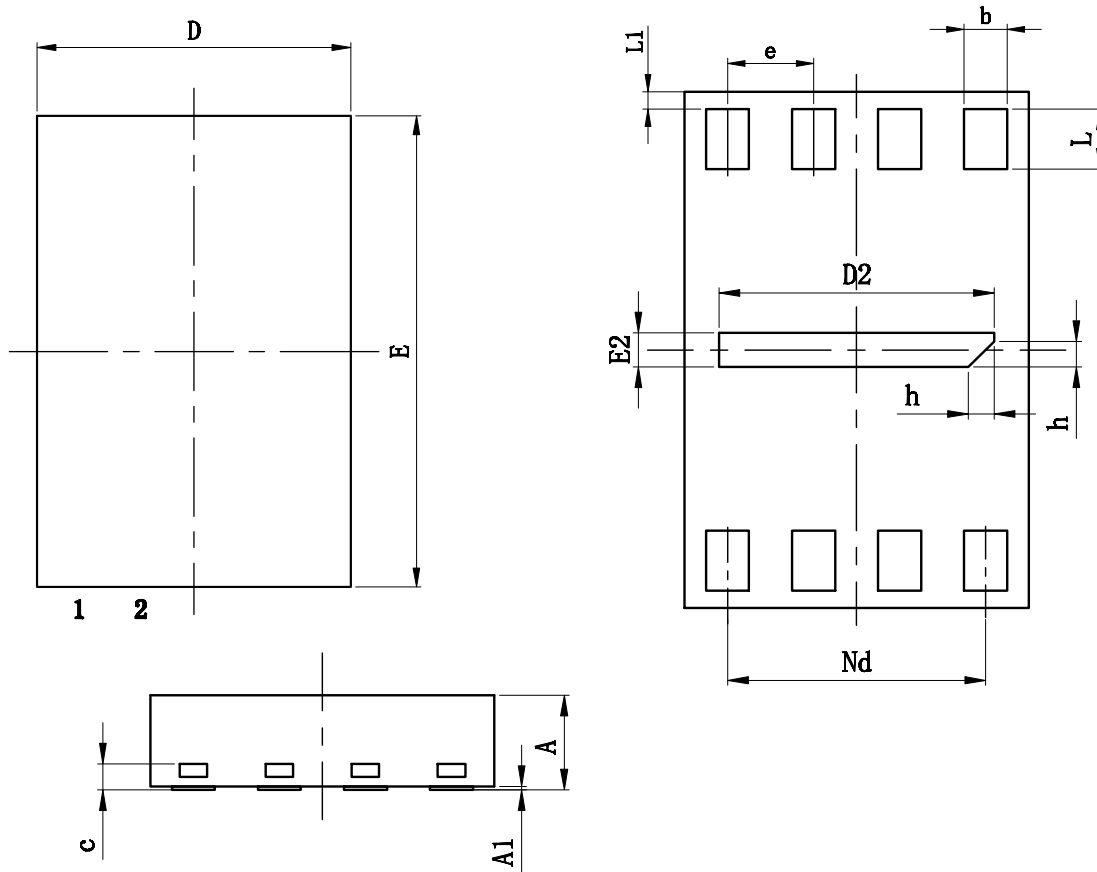

Symbol	Dimensions In Millimeters		Dimensions In Inch	
	Min	Max	Min	Max
A	0.500	0.600	0.020	0.024
A1	-	0.050	-	0.002
b	0.180	0.300	0.007	0.012
c	0.100	0.200	0.004	0.008
D	1.900	2.100	0.075	0.083
D1	1.500	1.700	0.059	0.067
e	0.500(BSC)		0.020(BSC)	
Nd	1.500(BSC)		0.059(BSC)	
E	2.900	3.100	0.114	0.122
E2	0.100	0.300	0.004	0.012
L	0.300	0.400	0.012	0.016
L1	0.050	0.150	0.002	0.006
h	0.050	0.250	0.002	0.010

7.8 Tube and Reel Information

Container	Tube
Quantity	2000pcs
Direction of feed	Direction of products is fixed in a container tube

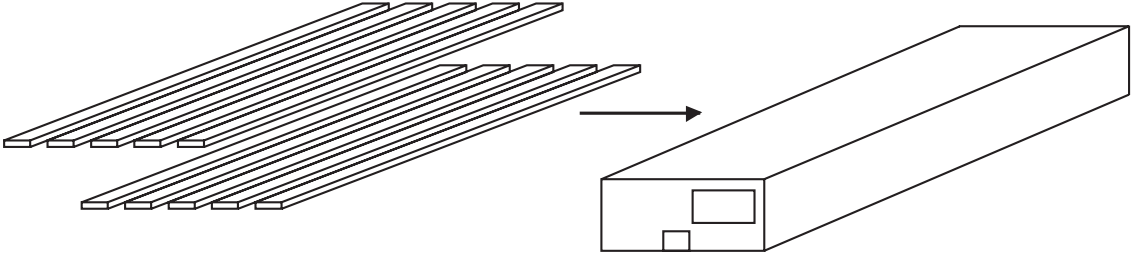

* Order quantity needs to be multiple of the minimum quantity.

Tape	Embossed carrier tape
Quantity	2500pcs (3000pcs for SOT23-5 AND DFN8 package)
Direction of feed	E2 (The direction is the 1pin of product is at the upper left when you hold reel on the left hand and you pull out the tape on the right hand)

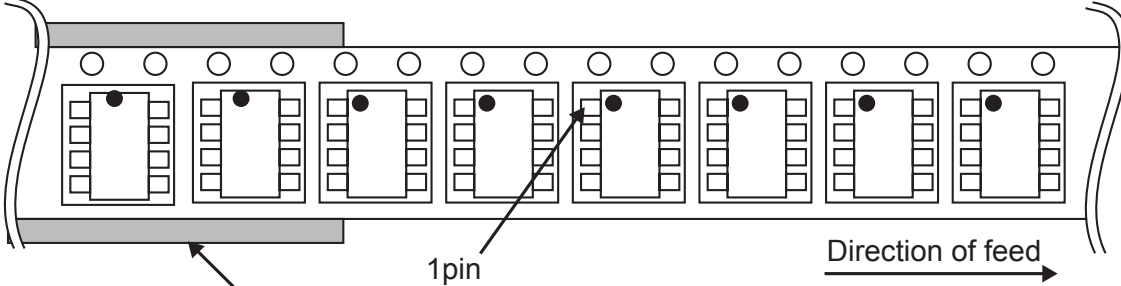

* Order quantity needs to be multiple of the minimum quantity.

8. Notice

●General Precaution

- 1) Before you use our Products, you are requested to carefully read this document and fully understand its contents. BM shall not be in any way responsible or liable for failure, malfunction or accident arising from the use of any BM's Products against warning, caution or note contained in this document.
- 2) All information contained in this document is current as of the issuing date and subject to change without any prior notice. Before purchasing or using BM's Products, please confirm the latest information with a BM sales representative.

●Precaution on using BM Products

1) Our Products are designed and manufactured for application in ordinary electronic equipments (such as AV equipment, OA equipment, telecommunication equipment, home electronic appliances, amusement equipment, etc.). If you intend to use our Products in devices requiring extremely high reliability (such as medical equipment, transport equipment, traffic equipment, aircraft/spacecraft, nuclear power controllers, fuel controllers, car equipment including car accessories, safety devices, etc.) and whose malfunction or failure may cause loss of human life, bodily injury or serious damage to property ("Specific Applications"), please consult with the BM sales representative in advance. Unless otherwise agreed in writing by BM in advance, BM shall not be in any way responsible or liable for any damages, expenses or losses incurred by you or third parties arising from the use of any BM's Products for Specific Applications.

2) BM designs and manufactures its Products subject to strict quality control system. However, semiconductor products can fail or malfunction at a certain rate. Please be sure to implement, at your own responsibilities, adequate safety measures including but not limited to fail-safe design against the physical injury, damage to any property, which a failure or malfunction of our Products may cause. The following are examples of safety measures:

[a] Installation of protection circuits or other protective devices to improve system safety

[b] Installation of redundant circuits to reduce the impact of single or multiple circuit failure

3) Our Products are designed and manufactured for use under standard conditions and not under any special or extraordinary environments or conditions, as exemplified below. Accordingly, BM shall not be in any way responsible or liable for any damages, expenses or losses arising from the use of any BM's Products under any special or extraordinary environments or conditions. If you intend to use our Products under any special or extraordinary environments or conditions (as exemplified below), your independent verification and confirmation of product performance, reliability, etc, prior to use, must be necessary:

[a] Use of our Products in any types of liquid, including water, oils, chemicals, and organic solvents

[b] Use of our Products outdoors or in places where the Products are exposed to direct sunlight or dust

[c] Use of our Products in places where the Products are exposed to sea wind or corrosive gases, including Cl₂, H₂S, NH₃, SO₂, and NO₂

[d] Use of our Products in places where the Products are exposed to static electricity or electromagnetic waves

[e] Use of our Products in proximity to heat-producing components, plastic cords, or other flammable items

[f] Sealing or coating our Products with resin or other coating materials

[g] Use of our Products without cleaning residue of flux (even if you use no-clean type fluxes, cleaning residue of flux is recommended); or Washing our Products by using water or water-soluble cleaning agents for cleaning residue after soldering

[h] Use of the Products in places subject to dew condensation

4) The Products are not subject to radiation-proof design.

5) Please verify and confirm characteristics of the final or mounted products in using the Products.

6) In particular, if a transient load (a large amount of load applied in a short period of time, such as pulse) is applied, confirmation of performance characteristics after on-board mounting is strongly recommended. Avoid applying power exceeding normal rated power; exceeding the power rating under steady-state loading condition may negatively affect product performance and reliability.

7) De-rate Power Dissipation (Pd) depending on Ambient temperature (Ta). When used in sealed area, confirm the actual ambient temperature.

8) Confirm that operation temperature is within the specified range described in the product

specification.

9) BM shall not be in any way responsible or liable for failure induced under deviant condition from what is defined in this document.

●**Precaution for Mounting / Circuit board design**

1) When a highly active halogen us (chlorine, bromine, etc.) flux is used, the residue of flux may negatively affect product performance and reliability.

2) In principle, the reflow soldering method must be used; if flow soldering method is preferred, please consult with the BM representative in advance. For details, please refer to BM Mounting specification

●**Precautions Regarding Application Examples and External Circuits**

1) If change is made to the constant of an external circuit, please allow a sufficient margin considering variations of the characteristics of the Products and external components, including transient characteristics, as well as static characteristics.

2) You agree that application notes, reference designs, and associated data and information contained in this document are presented only as guidance for Products use. Therefore, in case you use such information, you are solely responsible for it and you must exercise your own independent verification and judgment in the use of such information contained in this document. BM shall not be in any way responsible or liable for any damages, expenses or losses incurred by you or third parties arising from the use of such information.

●**Precaution for Electrostatic**

This Product is electrostatic sensitive product, which may be damaged due to electrostatic discharge. Please take proper caution in your manufacturing process and storage so that voltage exceeding the Products maximum rating will not be applied to Products. Please take special care under dry condition (e.g. Grounding of human body / equipment / solder iron, isolation from charged objects, setting of Ionizer, friction prevention and temperature / humidity control).

●**Precaution for Storage / Transportation**

1) Product performance and soldered connections may deteriorate if the Products are stored in the places where:

[a] the Products are exposed to sea winds or corrosive gases, including Cl₂, H₂S, NH₃, SO₂, and NO₂

[b] the temperature or humidity exceeds those recommended by BM

[c] the Products are exposed to direct sunshine or condensation

[d] the Products are exposed to high Electrostatic

2) Even under BM recommended storage condition, solder ability of products out of recommended storage time period may be degraded. It is strongly recommended to confirm solder ability before using Products of which storage time is exceeding the recommended storage time period.

3) Store / transport cartons in the correct direction, which is indicated on a carton with a symbol. Otherwise bent leads may occur due to excessive stress applied when dropping of a carton.

4) Use Products within the specified time after opening a humidity barrier bag. Baking is required before using Products of which storage time is exceeding the recommended storage time period.

●**Precaution for Product Label**

QR code printed on BM Products label is for BM's internal use only.

●**Precaution for Disposition**

When disposing Products please dispose them properly using an authorized industry waste company.

●**Precaution for Foreign Exchange and Foreign Trade act**

Since our Products might fall under controlled goods prescribed by the applicable foreign exchange and foreign trade act, please consult with BM representative in case of export.

●**Precaution Regarding Intellectual Property Rights**

1) All information and data including but not limited to application example contained in this document is for reference only. BM does not warrant that foregoing information or data will not infringe any intellectual property rights or any other rights of any third party regarding such

information or data. BM shall not be in any way responsible or liable for infringement of any intellectual property rights or other damages arising from use of such information or data.

2) No license, expressly or implied, is granted hereby under any intellectual property rights or other rights of BM or any third parties with respect to the information contained in this document.

● **Other Precaution**

1) The information contained in this document is provided on an “as is” basis and BM does not warrant that all information contained in this document is accurate and/or error-free. BM shall not be in any way responsible or liable for any damages, expenses or losses incurred by you or third parties resulting from inaccuracy or errors of or concerning such information.

2) This document may not be reprinted or reproduced, in whole or in part, without prior written consent of BM.

3) The Products may not be disassembled, converted, modified, reproduced or otherwise changed without prior written consent of BM.

4) In no event shall you use in any way whatsoever the Products and the related technical information contained in the Products or this document for any military purposes, including but not limited to, the development of mass-destruction weapons.

5) The proper names of companies or products described in this document are trademarks or registered trademarks of BM, its affiliated companies or third parties.

9. Revision History

Version	Publication Date	Pages	Revise Description
1.0	Apr.2016	23	Initial Document Release
1.0.1	Sep.2016	23	Revise Clerical Error of Naming Scheme
1.1	Jul.2017	23	Update Order Information
1.1.1	Aug.2017	23	Revise Byte Write Parameter
1.2	Apr.2021	23	Update Package Information